

ERGOX

CENTRAL VACUUM FOR CAR WASH

A NEW GENERATION OF CLEANING SYSTEM:

- more attractive for users
- maintenance-free for owners
- modern, highly efficient and energy-saving

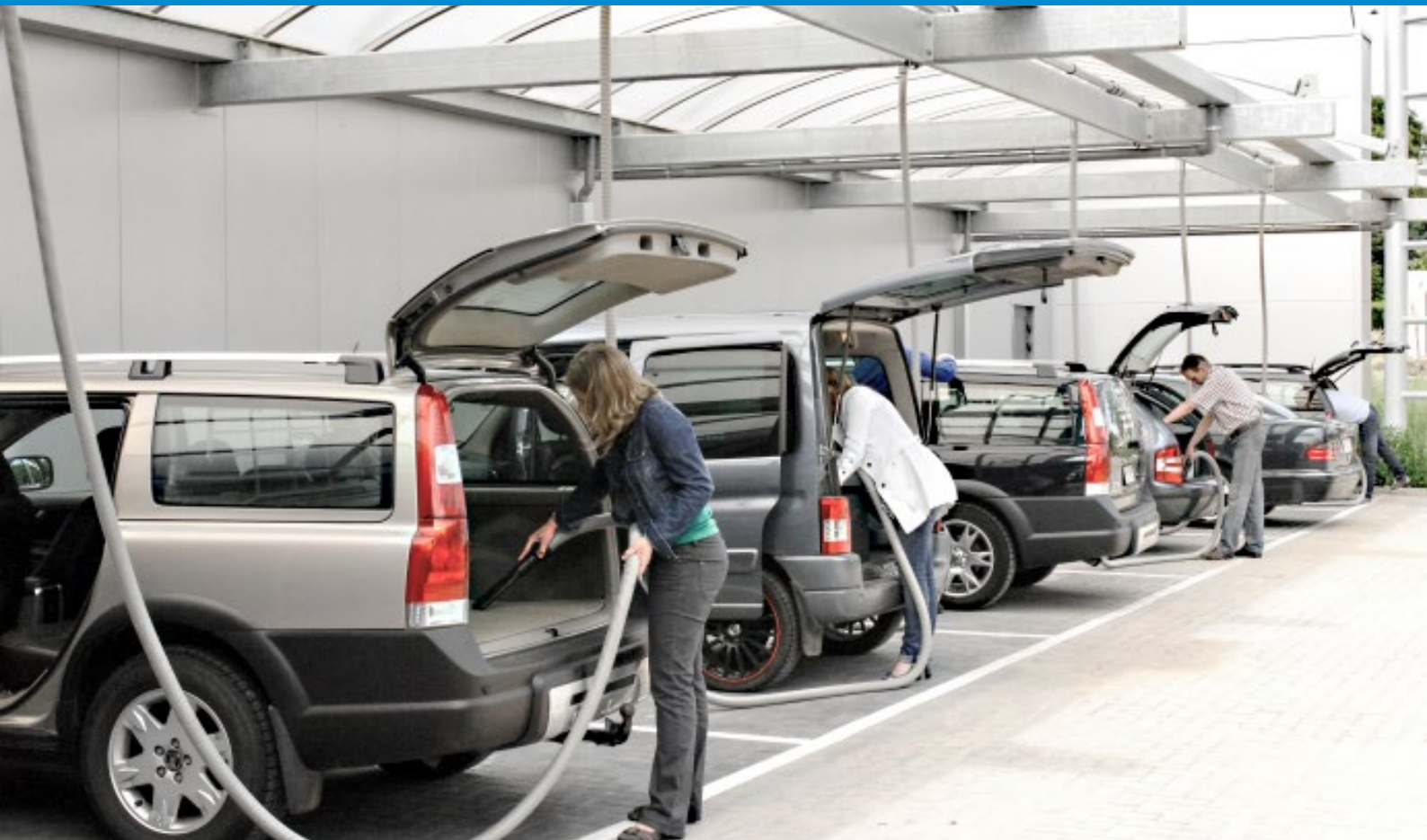

VACUUM CLEANING REDEFINED

Nowadays all carwashes are equipped with a **vacuum cleaning section**. Most of them use a traditional single-phase vacuum cleaner controlled by a coin timer, but the result is a poor performance, low efficiency, high cost of maintenance, high rate of failures and motor substitutions.

The evolution is represented by **central vacuum systems**: they have unquestionable advantages in terms of reliability and convenience. However, in the early days, only a primitive assembly was introduced, with rough parts and high-energy consumption.

▶ ERGOX **central vacuum system**, after long testing and expertise, improved every detail around the car wash vacuum:

- ▶ The systems equipped have reached more than 5.000.000 cleaned cars yearly without any trouble
An ERGOX system is absolutely reliable
- ▶ Ideal for self-service vacuum as well as for professional operators cleaning a rental fleet or prepping cleaned cars
An ERGOX system can be adapted to any setup
- ▶ Particular attention is given to energy consumption and efficiency in the long time, using complex control systems
An ERGOX system is economical & environmental friendly
- ▶ The car wash manager is called only for few ordinary operation: just emptying the dust container after some 1.500 cleaned cars
An ERGOX system is virtually maintenance free
- ▶ Big attention is given to design of car wash location
- ▶ Custom made

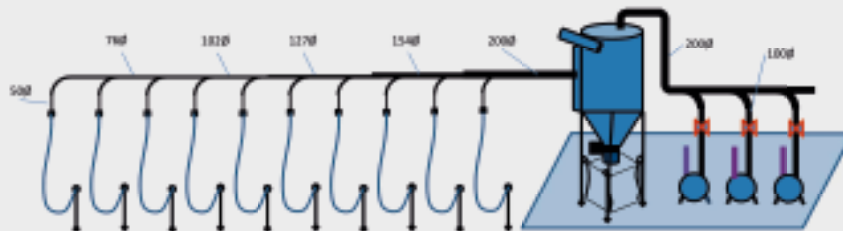

BENEFITS

FOR END USERS

The vacuum is really powerful and constantly strong, it is silent because motor is far away, it is convenient and quick, as the flexible hose is long and on both side of the car.

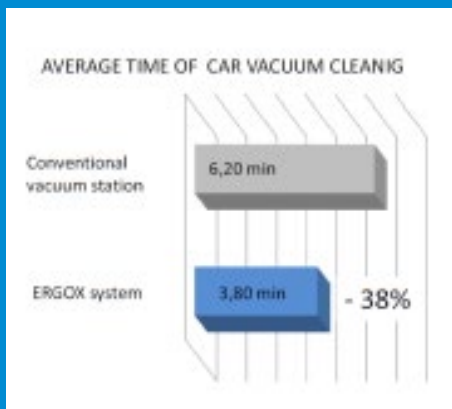

It is verified: "some drivers use a specific carwash only for central vacuum"



FOR CARWASH MANAGERS

Basically, the only maintenance is to empty the dust collector after an average of 1.250 cleaned cars. Filters are cleaned automatically with a reverse pulse jet and all the system performance is controlled with a PLC and differential pressure devices.

FOR THE ENVIRONMENT

Committed to keep our world healthier and cleaner: Ergox vacuum produces are powered by ultimate motors and inverter, reaching the Premium Efficiency Class IE3.

- Almost 97% of the cost of a motor in its life cycles is due to energy consumption and only 3% by initial cost of the motor.



ERGOX central system is mostly paid back in less than 2 years

PIPES & FITTINGS

Ergox originates from industrial central vacuum: there is an unparalleled range and available stock for pipelines. Stainless steel or zinc coated pipes, ells, elbows, compression couplings, etc.



PILLARS AND ROOFS

Special free standing pillar systems, hardtop, with or without sunscreens, optionally foreseen with integrated payment system and coin extraction system.



VACUUM VALVES

The gates are activated automatically, opening/closing airflow at each stall. Operate perfectly on every season condition or weathering.



MOTORS

Side channel blowers, the motor power ramps up from minimal consumption (1.8kW) to full speed when needed, cutting energy constantly. Tower installation for space saving available, as well as cage for sound suppression or external mounting.



FREQUENCY CONVERTER

The Siemens control for variable speed is the most reliable and with unparalleled I/O options. It is guaranteed for industrial continuous applications.



CONTROL BOX

The brain of the system is equipped with a programmable PLC for data elaboration and storage. In the 8" touch screen display all parameters of system can be easily read.



CYCLONIC PRIMARY SEPARATOR

In stainless steel, available in 3 different standards sizes or tailor made, can be placed even outside. With a true cyclonic filter detains 95% of vacuumed debris, wet or dry. This is the only part to be emptied on regular basis (from 1.200 to 2.500 cars).



FINE DUST SEPARATOR

It is basically for motor protection and to avoid contaminated air vented out. The industrial conceived filter is made of special treated polyester fibers and cleaned automatically by reverse pulse jet system. These cartridge filters are to be changed not sooner than 10 years.



COIN / TOKEN / BILL / CREDIT CARD ACCEPTORS

Ergox systems can be optimized for self-cleaning, both with free access or with toll. Centralized payment terminals or single electronic coin acceptors are available. Single coin acceptors come standard with the integrated Ergox coin extraction system.



HEAVY DUTY TOOL HOLDERS

Metal made with photocell to control the blast valves and airflow. A security check acts closing the valve after set time (default 8 minutes) of continuous use, to prevent accessory not restored in tool holder and limit reasonable service time. The tool holders are available for the crevice and claw tool.



ACCESSORIES

The flexible hoses are available in different colors, with 360° swivels cuffs, reinforced and crush proof, smooth inside and non-kinking. Air guns, free or paid use, for general cleaning of car interiors.



MULTIBOX AND CARPET CLAMP

All-in-one. Ergox combines waste bin, vacuum nozzle holder, compressed air and carpet clamp in one modern unit. The choice of RAL color and logo is possible on request.



FLEXIBLE AND ECONOMICAL

Whatever is the rate of occupancy of vacuum bays, there is always a controlled energy consumption, with optimal values of suction power and airflow. The electronic control is connected with filters and accessories with automatic differential pressure detectors keep filters cleaned and efficient.

If no station is activated, there is no energy consumption. With first user, there is less than 2 kW, that approximately is multiplied to every further user.

For this reason, the maximal consumption when for instance 16 users are vacuuming simultaneously, is about 24 kW.



All the system parameters: power per user, cycles, working hours, dust level and others can be monitored and stored on the touch screen display of the control board, mounted in remote control room. It gives also the possibility to follow up and check the incoming payments.



WORLDWIDE



Barcelona, Spain



Canberra, Australia



Middelburg, Netherlands



Asslar, Germany



Oostakker, Belgium



Rastatt, Germany



Sint-Petersburg, Russia



Denderleeuw, Belgium



Tiller, Norway

ERGOX SYSTEM DESIGN

No matter the size, Ergox delivers optimal solutions from 2 to 50 drops. Free conceptual rendering and system layout, turnkey installations, turnover attendance and break even forecast.



ON-SITE CONSULTING

Ergox can install directly or through its distributors all over Europe. As alternative, only material can be supplied and supervised by local installers, providing them with illustrated manuals and accurate installation procedures.

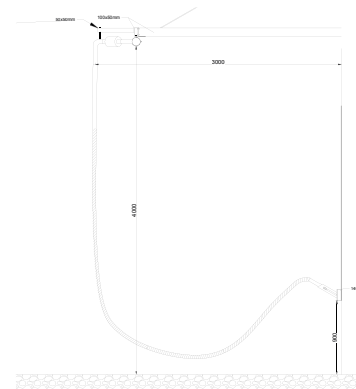
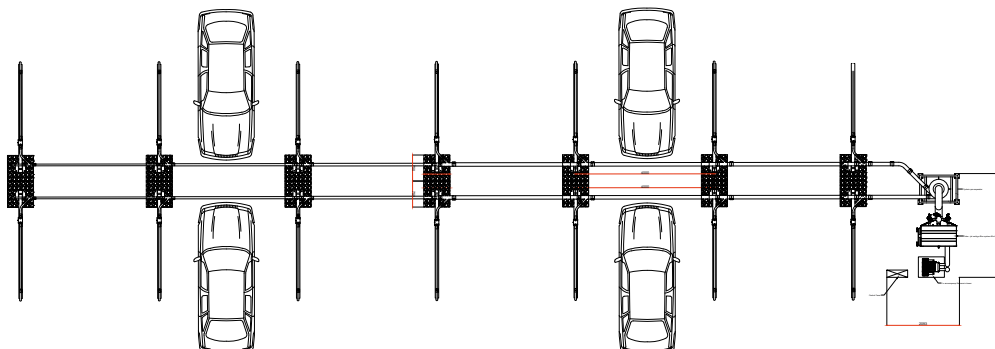



ERGOX

ERGOX BVBA

Venlosesteenweg 149
3680 Maaseik
BELGIUM

Tel. +32 89 244 529
www.ergox.com
info@ergox.com

